

### Sequence Modular Valve

40 to 80 ℓ /min  
25MPa



### Features

- ① This modular valve is a pressure control valve used for sequential actuator operations and for maintaining main circuit pressure.
- ② Pressure adjustment is possible across a wide range, from 0.25 to 21MPa {1.5 to 214 kgf/cm<sup>2</sup>}.
- ③ Maximum Operating Pressure: , 25MPa {255kgf/cm<sup>2</sup>}

### Specifications

Model No.	Nominal Diameter (Size)	Maximum Working Pressure MPa{kgf/cm <sup>2</sup> }	Maximum Flow Rate ℓ /min	Pressure Adjustment Range MPa{kgf/cm <sup>2</sup> }	Weight kg	Gasket Surface Dimensions
OQ-G01-P21-20 P23	1/8	25{255}	40	0.8 to 7 { 8.2 to 71.4} 3.5 to 21{35.7 to 214}	1.1	ISO 4401-03-02-0-94
OQ-G03-P2A-J50 P2C P2E	3/8	25{255}	80	0.25 to 0.85{ 2.5 to 8.7} 0.85 to 3.5 { 8.7 to 35.7} 3.5 to 14{35.7 to 143}	3.5	ISO 4401-05-04-0-94

### Understanding Model Numbers

OQ - G 03 - P 2 A - (K) - J50

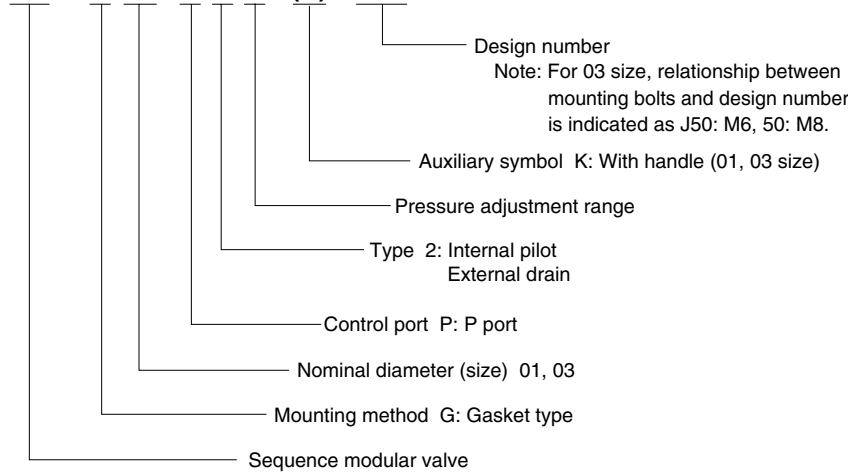

#### ● Handling

- ① The pressure adjustment range is expressed in terms of cracking pressure.
- ② Install this valve directly above the sub plate or manifold.
- ③ When two or more of these valves are ganged in sequence, make sure the setting pressure differential between them is at least 1MPa {10.2kgf/cm<sup>2</sup>}.
- ④ Note that a sub plate and installation bolts are not included. See pages D-90 through D-95 if these items are required.

### Installation Dimension Drawings

Note) Pressure is increased by clockwise (rightward) rotation of the adjusting screw (bolt), and decreased by counterclockwise (leftward) rotation.

OQ-G01-P2\*-20

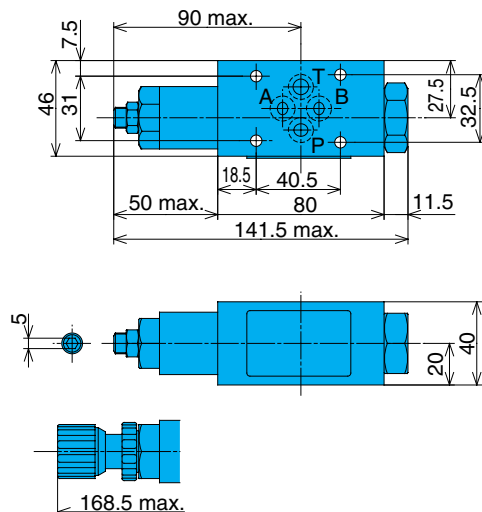

OQ-G03-P2\*-J50

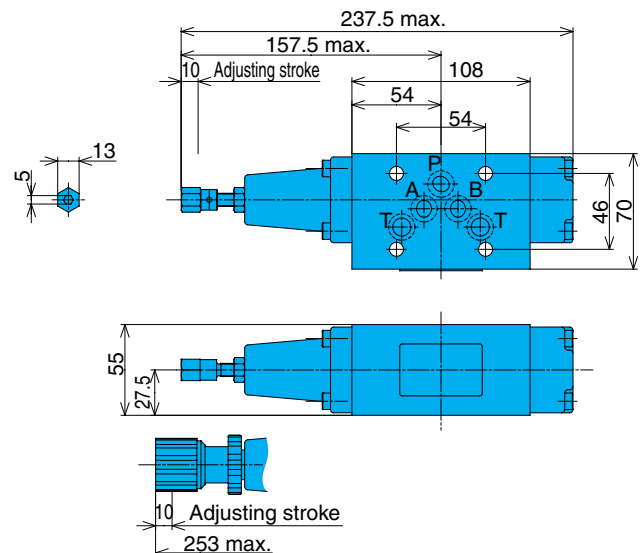

# Performance Curves

Hydraulic Operating Fluid Viscosity 32mm<sup>2</sup>/s

## Pressure Loss Characteristics

OQ-G01-P2\*-20

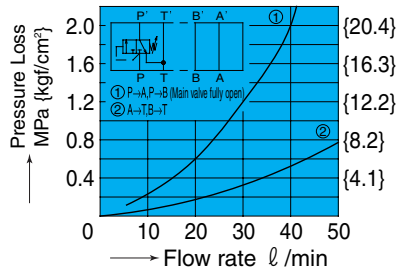

OQ-G03-P2A-J50

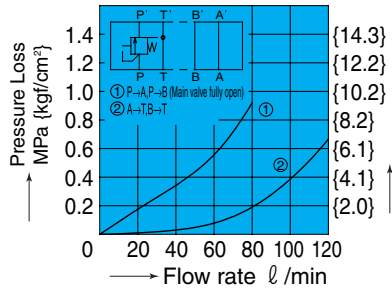

## Pressure — Flow Rate Characteristics

OQ-G01-P2\*-20

— Pressure Rise  
--- Pressure Drop

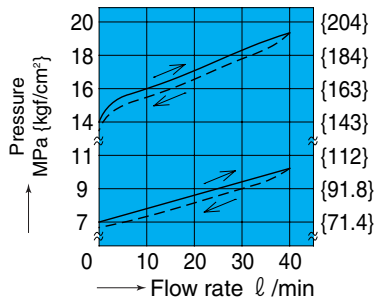

OQ-G03-P2\*-J50

— Pressure Rise  
--- Pressure Drop

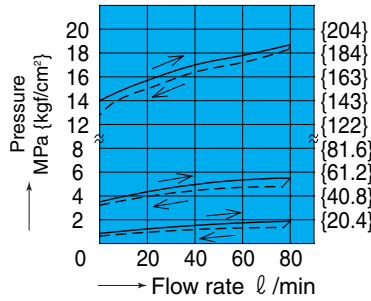

## Number of Adjusting Screw Rotations — Pressure Characteristics

OQ-G01-P2\*-20

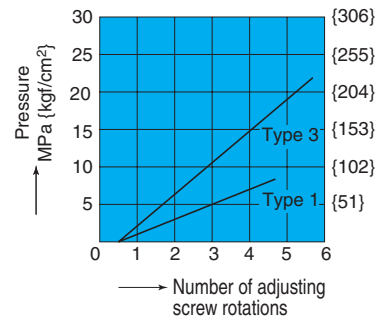

OQ-G03-P2\*-J50

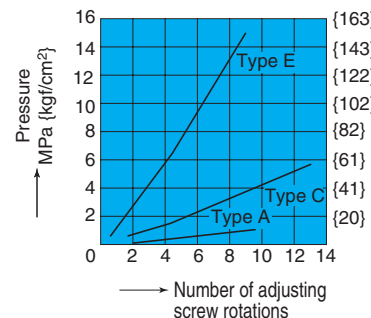

# Cross-sectional Drawing

OQ-G01-P2\*-20

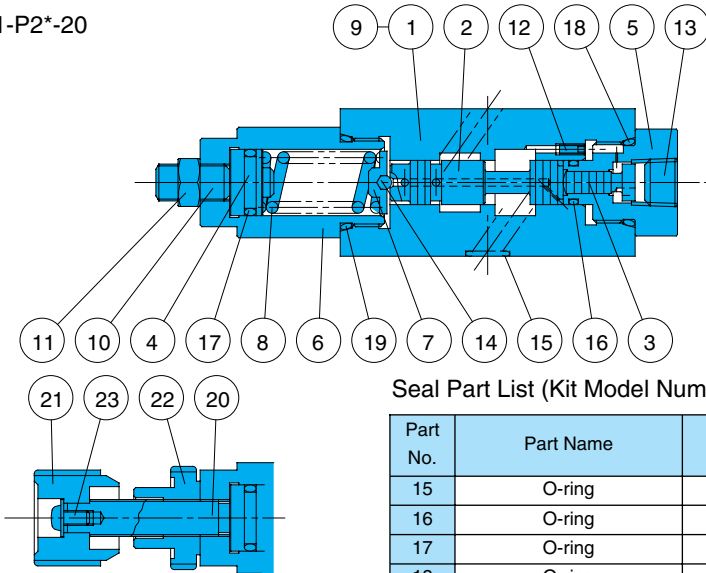

Seal Part List (Kit Model Number BRBS-01QP)

Part No.	Part Name	Part Number	Q'ty	
			P	
15	O-ring	1B-P9	4	
16	O-ring	1B-P9	1	
17	O-ring	1A-P14	1	
18	O-ring	1B-P20	1	
19	O-ring	1B-P22	1	

Note) O-ring 1A/B-\*\* refers to JIS B2401-1A/B.

Part No.	Part Name
1	Body
2	Spool
3	Piston
4	Plunger
5	Bushing
6	Retainer
7	Guide
8	Spring
9	Plate
10	Screw
11	Nut
12	Choke
13	Plug
14	Ball
15	O-ring
16	O-ring
17	O-ring
18	O-ring
19	O-ring
20	Screw
21	Knob
22	Nut
23	Screw

OQ-G03-P2\*-J50

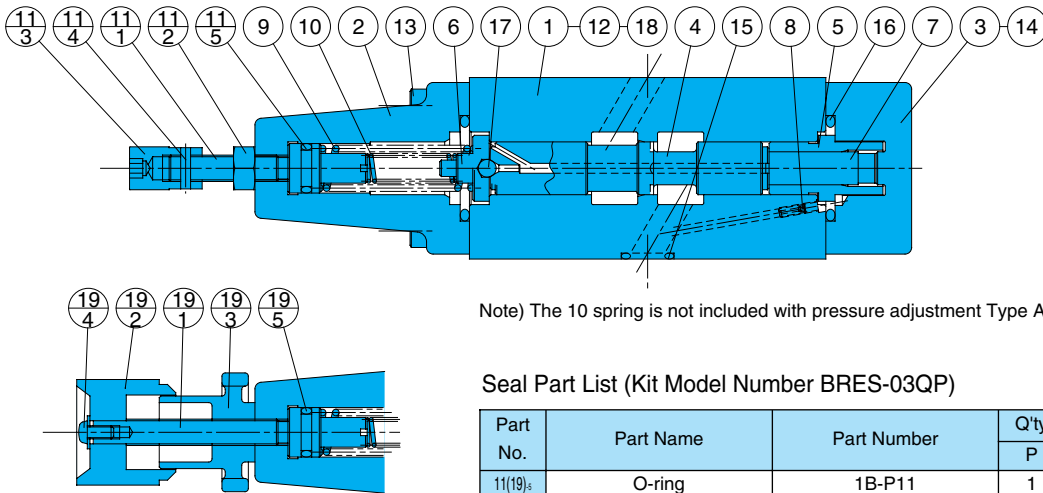

Note) The 10 spring is not included with pressure adjustment Type A.

Seal Part List (Kit Model Number BRES-03QP)

Part No.	Part Name	Part Number	Q'ty	
			P	
11(19) <sub>5</sub>	O-ring	1B-P11	1	
15	O-ring	AS568-014(Hs90)	5	
16	O-ring	1B-P26	2	

Note) O-ring 1A/B-\*\* refers to JIS B2401-1A/B.

Part No.	Part Name
1	Body
2	Cover
3	Cover
4	Spool
5	Sleeve
6	Guide
7	Plunger
8	Choke
9	Spring
10	Spring
11	Screw kit
11-1	Screw
11-2	Nut
11-3	Nut
11-4	Pin
11-5	O-ring
12	Plate
13	Screw
14	Screw
15	O-ring
16	O-ring
17	Ball
18	Pin
19	Handle kit
19-1	Screw
19-2	Knob
19-3	Nut
19-4	Screw
19-5	O-ring